



FHOSS  **ILLUMINATED**
SMART WALKWAYS

SYSTEM GUIDE

KEEPING PEOPLE PROTECTED FROM PLANT, DAY AND NIGHT.

Designed with your workforce in mind, our patent-pending Smart Illuminated Walkway system allows us to bridge the gap between people and plant.

Communication between the two has been a challenge on-site until now, through the simple use of visual messaging, your workers and site visitors can traverse with confidence and peace of mind.

We all know the consequences of accidents on site, mitigate risks in the people-plant interface - no matter the weather, with FHOSS Smart Illuminated Walkways. Be safe, be seen.

WHY DO YOU NEED SMART ILLUMINATED WALKWAYS?

With health and safety at the forefront of our minds today, it is undeniably important that we read and understand the current statistics, from the most significant dangers to workers to the effect that lost time and prosecution have on businesses and the country as a whole.

A short synopsis here of the latest statistics released by HSE gives us an overview of the frequency of ill health in the construction sector, the reasons for it, the cost of injury and the most significant risks to workers.

With vehicles as dangerous on-site as they are, Smart Illuminated Walkways allow people to communicate with plant, quickly, effectively and non-verbally. This step forward from the basic crossing found on the majority of sites creates a sense of synergy on-site, as workers on the ground can broadcast their location to operators in any weather or light conditions.

"There were 143 prosecution cases led by HSE or, in Scotland, the Crown Office and Procurator Fiscal where a verdict was reached in 2019/20p, resulting in:

- 137 (96%) with a conviction for at least one offence;
- £8.3 million in total fines averaging over £60,000 per conviction.
- In 2018/19 there were 157 cases resulting in 146 convictions (93%); this led to £18.5 million total fines and average fines of around £126,000."

Source: <https://www.hse.gov.uk/statistics/>

81,000

Workers suffering from work-related ill health (new or long-standing).

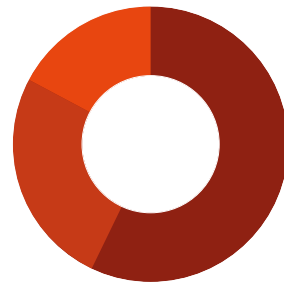

- Musculoskeletal Disorders 57%
- Stress, Depression or Anxiety 26%
- Other 17%

Source: RIDDOR, 2015/16-2019/20. Accident kinds are shown for the top five RIDDOR, 2019/20 causes of fatal injuries.

The rate of self-reported work-related ill health has been broadly flat in recent years.

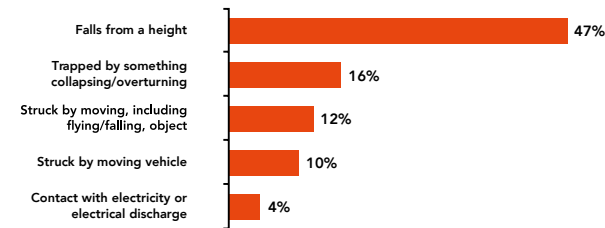

Source: LFS estimated annual average 2017/18-2019/20

Economic cost of workplace injury and new cases of work-related ill health in Construction



Source: HSE Costs to Britain, 2018/19. Workplace injury and ill health impose costs: both financial (for example in terms of lost output and healthcare costs) and non-financial (the monetary valuation of the human cost of injury and illness in terms of loss of quality of life, and for fatalities, loss of life). Taken together, this gives the total economic cost to society. This cost is shared between individuals, employers and government/taxpayers. For workplaces with five or more employees reporting the presence of various workplace risks, regardless of whether risk is under control.

Percentage of workplaces in the Construction sector reporting the presence of workplace risks.

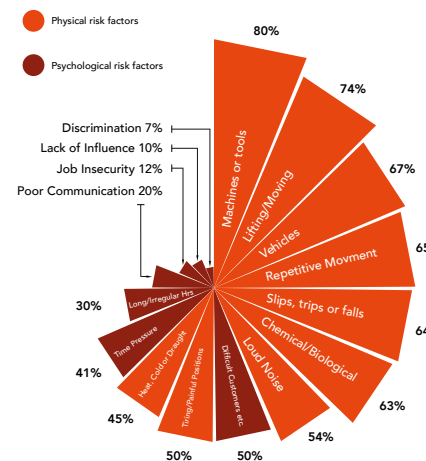

Percentage of workplaces in the Construction sector reporting the presence of workplace risks.

- Physical risks were more commonly reported than psychosocial risks
- Although 'machines or tools' was the top risk, accidents with machinery account for between 2-6% of reported fatal and non-fatal injuries
- The main psychosocial risks related to difficult customers and time pressure

Source: A 2014 survey, commissioned by the European Union Occupational Safety and Health Agency (in collaboration with the Health and Safety Executive), explored the extent that various risks are present in the workplace (regardless of whether the risk is under control), as reported by the person who knows most about safety and health in the workplace. The chart shows the extent of these various risk factors in workplaces in the Agriculture, forestry and fishing sector in the UK. Full details of the UK results, including measures of how risks are managed within the sector can be found at www.hse.gov.uk/statistics/cshman.htm. The source is known as ESENER 2014. For workplaces with five or more employees reporting the presence of various workplace risks, regardless of whether risk is under control.

SMART WALKWAY SYSTEM GUIDE.

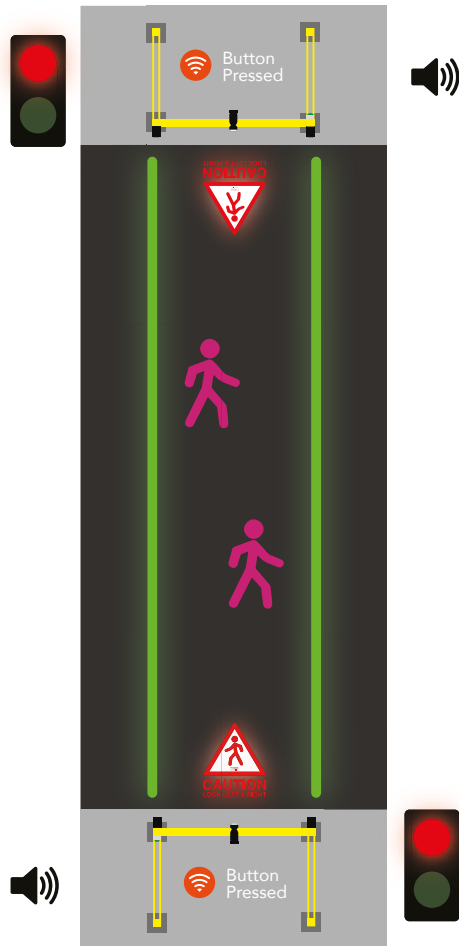

In Use

The FHOSS Smart Illuminated Walkway system is hard wired into its environment and allows workers and patrons to clearly identify exclusion zones in a variety of colours.

Once the system is installed, focused beams of light will signify not only the crossing zone for workers but also when said crossing zone is safe to use.

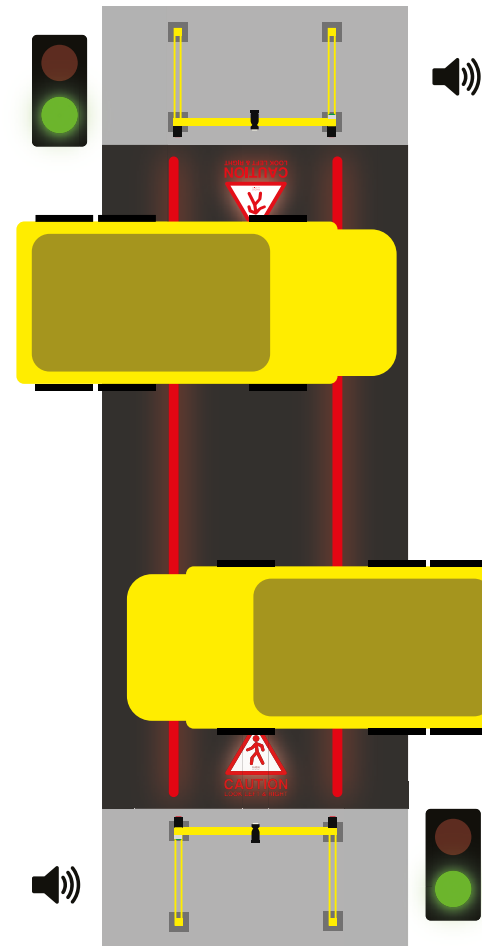

Standby

The system will simultaneously convey the opposite message to any oncoming drivers. Letting them know that the crossing is in use.

Each side of the system is wireless, therefore no trenches need to be dug up to install the system, meaning no down time for your site.

OUR FRAMEWORK SOLUTION.

In-line with our belief in only the highest quality fit and finish - we offer a FHOSS approved framework for your Smart Walkway system. We use IP67 rated, powder-coated aluminium frame that's sure to withstand the test of time on your site.

1 Traffic Light

Red & green LED traffic light, set to green by default, turning red when button is pressed.

2 FHOSS CAST Projector

Our recent visual messaging innovation, FHOSS CAST, allows us to project any design onto any surface. A "Caution, Look Left and Right" message in this case.

3 2x FHOSS HALO Lines

Red & green HALO Exclusion Zone line lights. Having adjusted our design, the HALO opens up an entirely new set of functions. In this case, it demarkates the lines alongside the crossing.

4 Push Button

A simple, reliable, intuitive design. All the pedestrian, worker or visitor needs to do is press and wait for the visual and audio signals of the HALOs and sounder.

5 Control Box

The brains of the operation, our control boxes are IP67 rated to ensure that your system can withstand whatever your site throws at it.

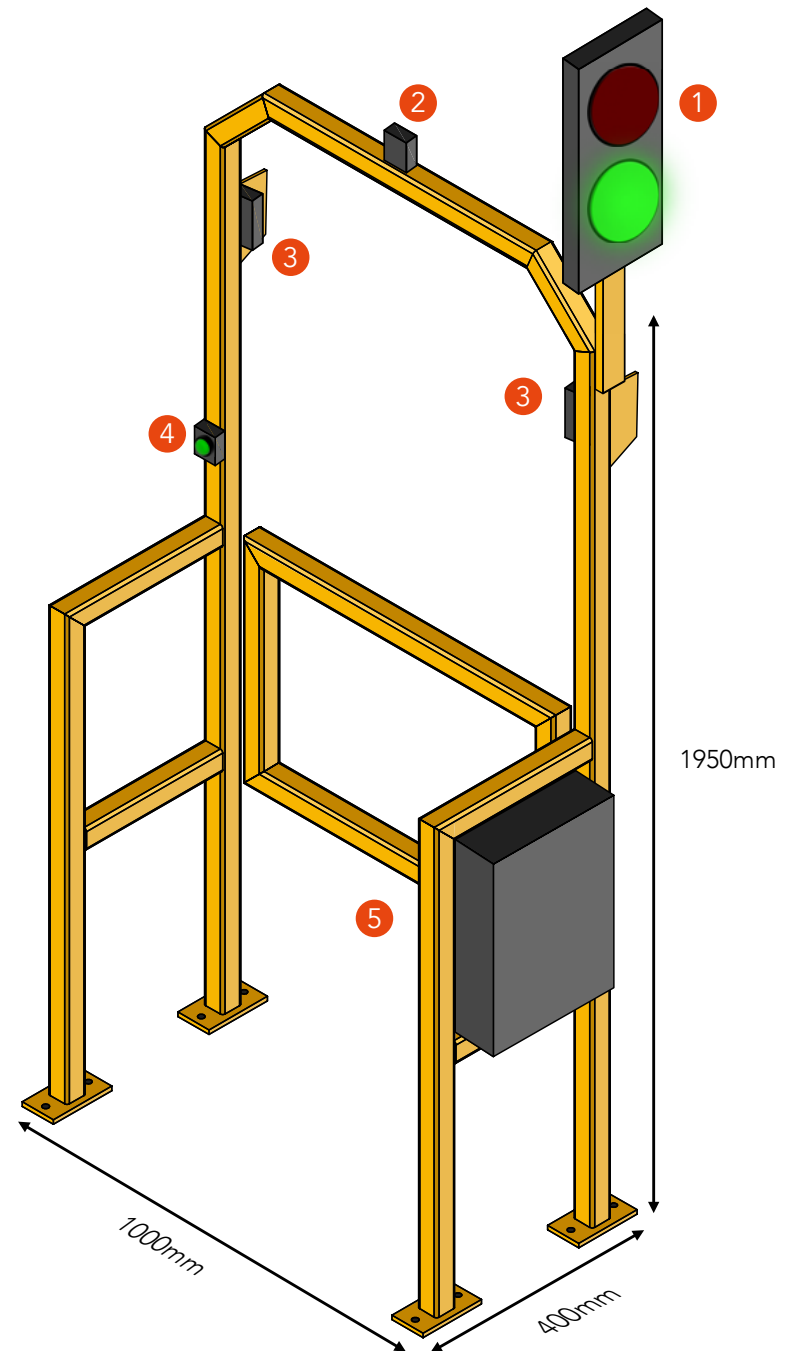

IN USE / CROSS

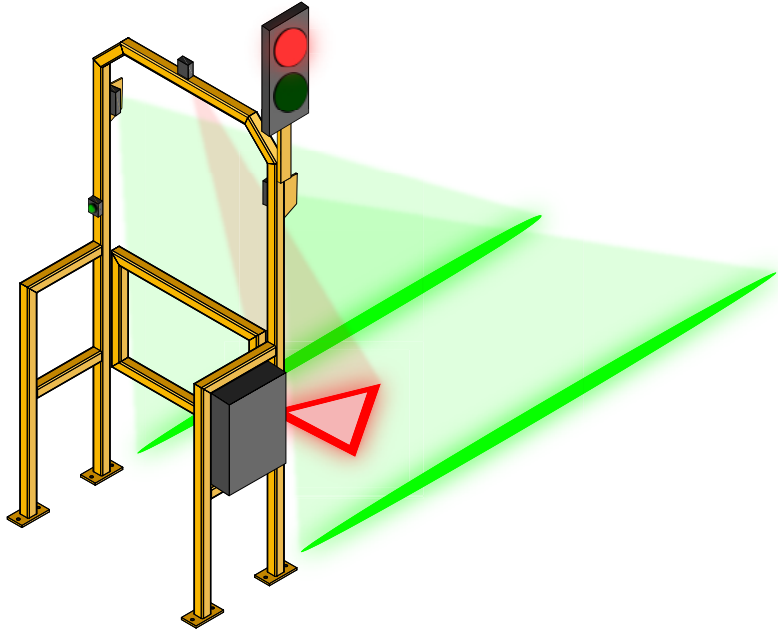

STANDBY / WAIT

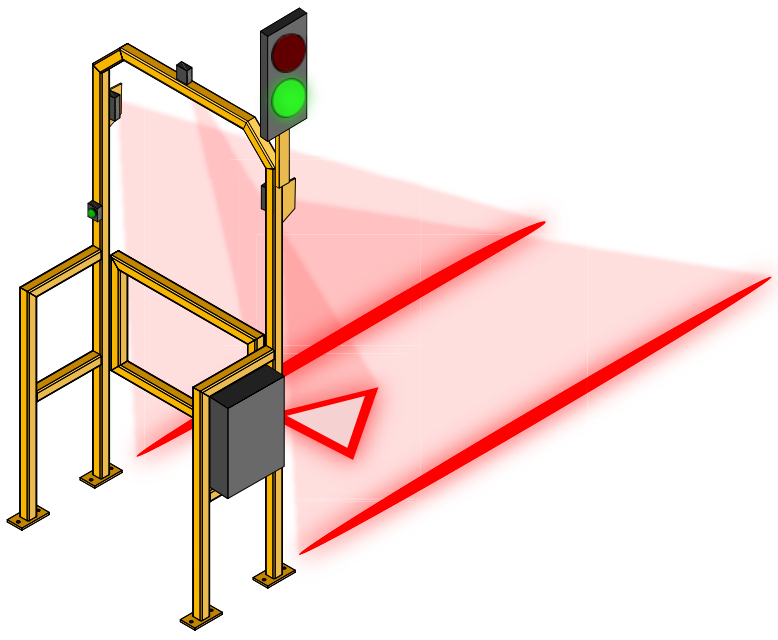

FREQUENTLY ASKED QUESTIONS.

Our dedicated team of safety specialists are on hand to answer any questions and to offer advice on the best placement and usage of our safety systems.

We work closely with our partners and clients to ensure we are up to date with the latest methods and working practices which means we are so much more than just another supplier.

Q: Does it work in the day?

A: Yes, our Illuminated Smart Walkway functions as a standard traffic light system in the day, given that the HALO lamps point towards the pedestrian.

Q: Is downtime required for installation?

A: No, the system works wirelessly and therefore requires no trenches to be dug.

Q: How long does installation take?

A: Our teams can install the Walkway in a day.

Q: Will the lines rub off over time?

A: Due to the nature of our HALO lights, we project the lines onto the topmost layer of the surface. Water, dirt, snow etc will all allow the lines to show.

Q: How far can the crossing project?

A: We can project beams across 25m using two frameworks, and as many as need be can be added to create a wider crossing.

Q: Will the system function in adverse weather?

A: Yes, Walkway will function in all conditions, every element is IP67 rated.

Q: How robust is the system?

A: Our system has been in testing for the last few years, staying perfectly functional in the harshest aggregate & quarrying conditions. With the correct maintenance, Smart Walkway is built to outlast any other crossing solution.

Q: Is the system waterproof?

A: Yes, Illuminated Smart Walkways are IP67 rated across the board, and will work fine in any condition.

ORDER PROCESS AND INSTALLATION.

We work closely with our partners and clients to ensure we are up to date with the latest methods and working practices which means we are so much more than just another supplier.

Our dedicated team of safety specialists are on hand to answer any questions and to offer advice on the best placement and usage of our safety systems. Once we've agreed the right system for your requirements, we will arrange a mutually convenient time and location to fit your equipment.

Our highly skilled FHOSS engineers are fully trained and equipped to carry out your install with the minimum of fuss in a professional and timely manner, with no downtime or digging onsite.

We offer both installation and setup of the system itself, as well as an all inclusive package that includes the framework for our equipment to sit on - all part of the price.

In the unlikely event of breakdown, installs and equipment are covered by a 12 month manufacturing defects warranty giving you complete peace of mind. If this does occur, we will endeavour to get an engineer to you as soon as possible ensuring minimum downtime.

Please don't hesitate to get in contact to see how FHOSS can help improve the safety of you and your workforce.

Please contact our sales account managers for pricing options. (Financing options available.)

T: 0333 003 5710

E: sales@enfieldsafety.co.uk

A: Langley House,
Station Road,
Standon,
Herts.
SG11 1QN

Social Media Links:



FHOSS ILLUMINATED SMART WALKWAYS

Enfield
Safety. Delivered.

BE SAFE, BE SEEN.

t: 0333 003 5710 e: sales@enfieldsafety.co.uk w: www.enfieldsafety.co.uk

